

# DishDrawer

## Models

DD601 DD601I DD601V2  
DD601V2I DD602 DD602I  
DS601 DS601I DS601V2  
DS601V2I DS602 DS602I

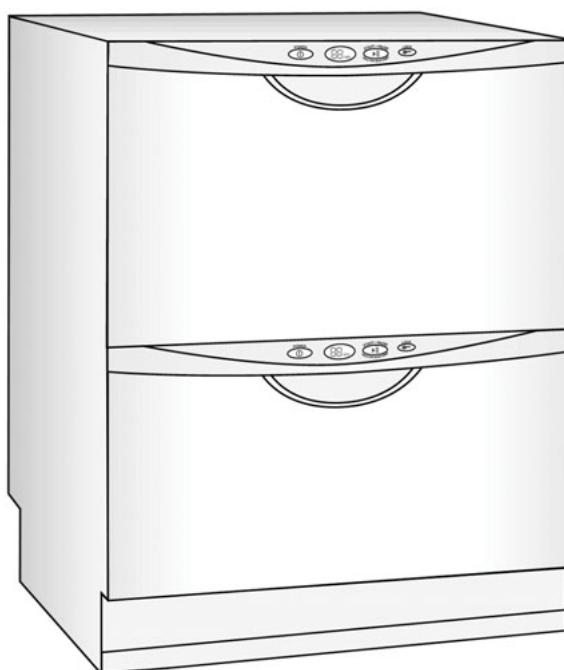



## PRODUCTS

**Brand** Fisher & Paykel

**Voltage** 220-240V 50Hz, 110-120V 50Hz\*

Model	Series	Code
DD601	0	87225 87448
DD601I	0	87446
DD601V2	0	87508 87516 87543 87545 87546 87547
DD601V2I	0	87548
DD602	0	88244* 88245* 88246* 88252*
DD602I	0	88247*
DS601	0	87490 87494
DS601I	0	87498
DS601V2	0	87521 87523 87549 87551
DS601V2I	0	87550
DS602	0	88248* 88249* 88250*
DS602I	0	88251*

Customer Care Centre  
 Fisher & Paykel  
 P.O. Box 58732  
 Greenmount, Auckland  
 Phone: 0800 FP CARE  
 (0800 37 2273)  
 Fax: +64-9-2730656  
 Email: [Customer.Care@fp.co.nz](mailto:Customer.Care@fp.co.nz)

Customer Care Centre  
 Fisher & Paykel  
 P.O. Box 798  
 Cleveland, QLD 4163  
 Phone: 1 300 650 590  
 Fax: +61-7-3826 9298  
 Email: [Customer.Care@fp.com.au](mailto:Customer.Care@fp.com.au)

Fisher & Paykel Customer Services  
 27 Hubble  
 Irvine, California  
 CA 92618 USA  
 Tel: 1 888-936-7872  
 Fax: 1 949-790-8913  
 Email: [customer.care@fisherpaykel.com](mailto:customer.care@fisherpaykel.com)



## CONTENTS

FRONT PANELS AND CONTROLS.....	8
CABINET.....	10
DRAWER LID AND AIR PUMP.....	14
TUB AND COMPONENTS.....	16
BASKETS AND RACKS.....	18
WIRING HARNESES.....	20
INSTALLATION COMPONENTS.....	22
NOTES.....	27

### GUIDE TO USING THIS MANUAL

The model(s) and/or series covered by this manual are listed on the front cover.

The information detailed in this manual is subject to change without notice, the latest version is indicated by the manual date and replaces any earlier editions.

The front cover picture shows the type of product and may not necessarily be an exact image of the models covered by the manual.

#### Part References

Where a Model is shown, the part is exclusive to the Model(s) stated.

#### Kit Parts

The components shown in *italics* are those parts in the kit which are available also as separate items.

All details relating to Technical Bulletins or Notes are shown on a dedicated page.

#### Parts List Key

NOT USED	As a part, indicates the diagram part reference is not used in this manual.
#	Beside the part number, indicates the part is no longer available.
<i>italics</i>	Kit components shown in <i>italics</i> are also available separately.
*	Indicates a technical bulletin or note exists for the part or part reference.
NI	As a part reference, indicates the part is not illustrated on the diagram.

# FRONT PANELS AND CONTROLS

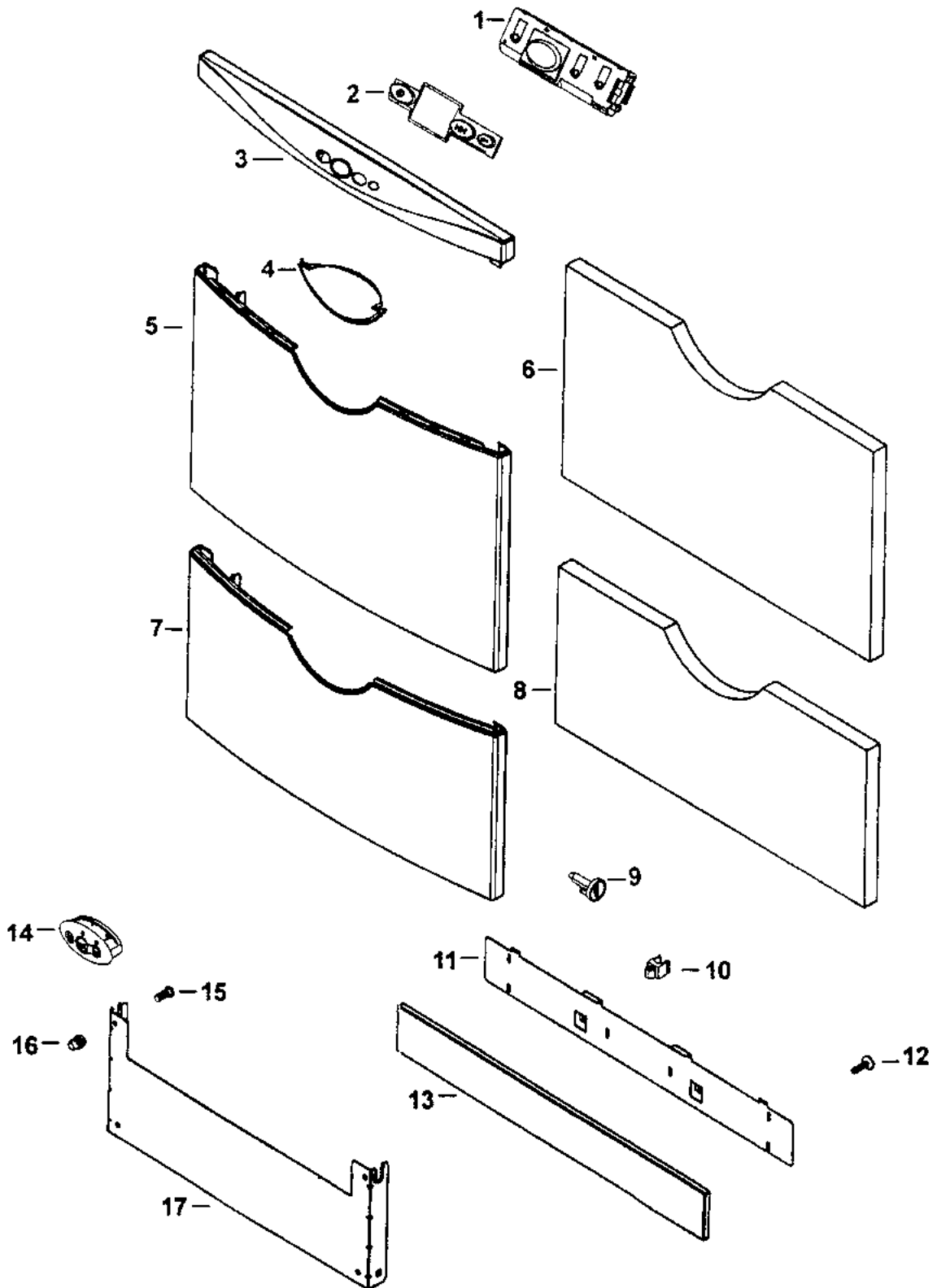

**FRONT PANELS AND CONTROLS**

<b>REF</b>	<b>PART</b>	<b>DESCRIPTION</b>	<b>MODEL</b>
1	525192P	CONTROLLER LCD PCB ASSY	
2	525196	KEYPAD WHITE	
	525727	KEYPAD BLACK	
3	525712	HANDLE LCD PREFINISH WH PRN	
	525789	HANDLE LCD PREFINISH BK PRN	
	526160	HANDLE LCD PREFINISH SS PRN V2	
	526218	KIT HANDLE WH TUB GRAPHICS	
	526219	KIT HANDLE SS TUB GRAPHICS	
	526220	KIT HANDLE BK TUB GRAPHICS	
4	525211	RECESS DOOR WHITE	
	525731	RECESS DOOR BLACK	
	525734	RECESS DOOR SS	
5	525748	DOOR UPPER ASSY WHITE F&P	
	525858	DOOR UPPER ASSY STAINLESS F&P	
	525859	DOOR UPPER ASSY BLACK F&P	
	525748	DOOR UPPER ASSY WHITE FP PH2	
	525858	DOOR UPPER ASSY SS FP PH2	
6	526190	INSUL DOOR UPPER	
7	525749	DOOR LOWER ASSY WHITE	
	526027	DOOR LOWER ASSY WHITE PH2 US	
	525860	DOOR LOWER ASSY STAINLESS	
	526028	DOOR LOWER ASSY SS PH2 US	
	525861	DOOR LOWER ASSY BLACK	
	526029	DOOR LOWER ASSY BLACK PH2 US	
8	526189	INSUL DOOR LOWER	
9	525010	PIN DOOR	
10	525290	CLIP PANEL KICKSTRIP	
11	525285	PANEL KICKSTRIP	
12	556091P	SCREW ST M3X8PLASTITE PKT10	

# FRONT PANELS AND CONTROLS

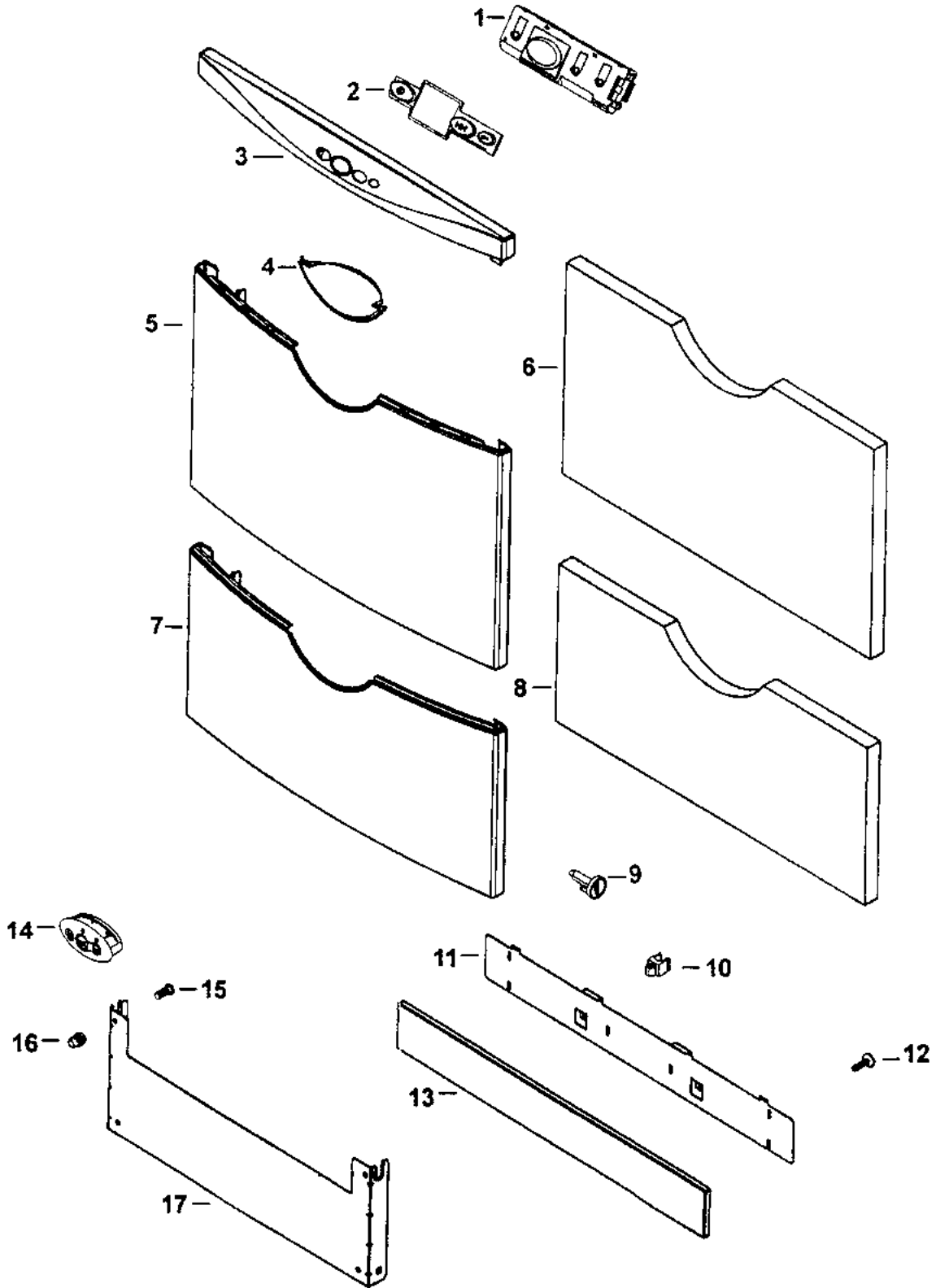



**FRONT PANELS AND CONTROLS**

<b>REF</b>	<b>PART</b>	<b>DESCRIPTION</b>	<b>MODEL</b>
13	525337	KICKSTRIP COSMETIC TOP WHITE	
	525722	KICKSTRIP COSMETIC TOP BLACK	
14	* 525185P	BADGE ASSY INTEGRATED CHROME	
	526691	BADGE ASSY BLACK	
	526033	BADGE ASSY SS (SP)	
15	556098P	SCREW MC M6X14 PAN PH MS PKT10	
16	525464P	NUT M6 TYPE E PKT10	
17	525203	PANEL DOOR INTEGRATED	
NI	525839	TRIM INTEGRATED GREY	

# CABINET

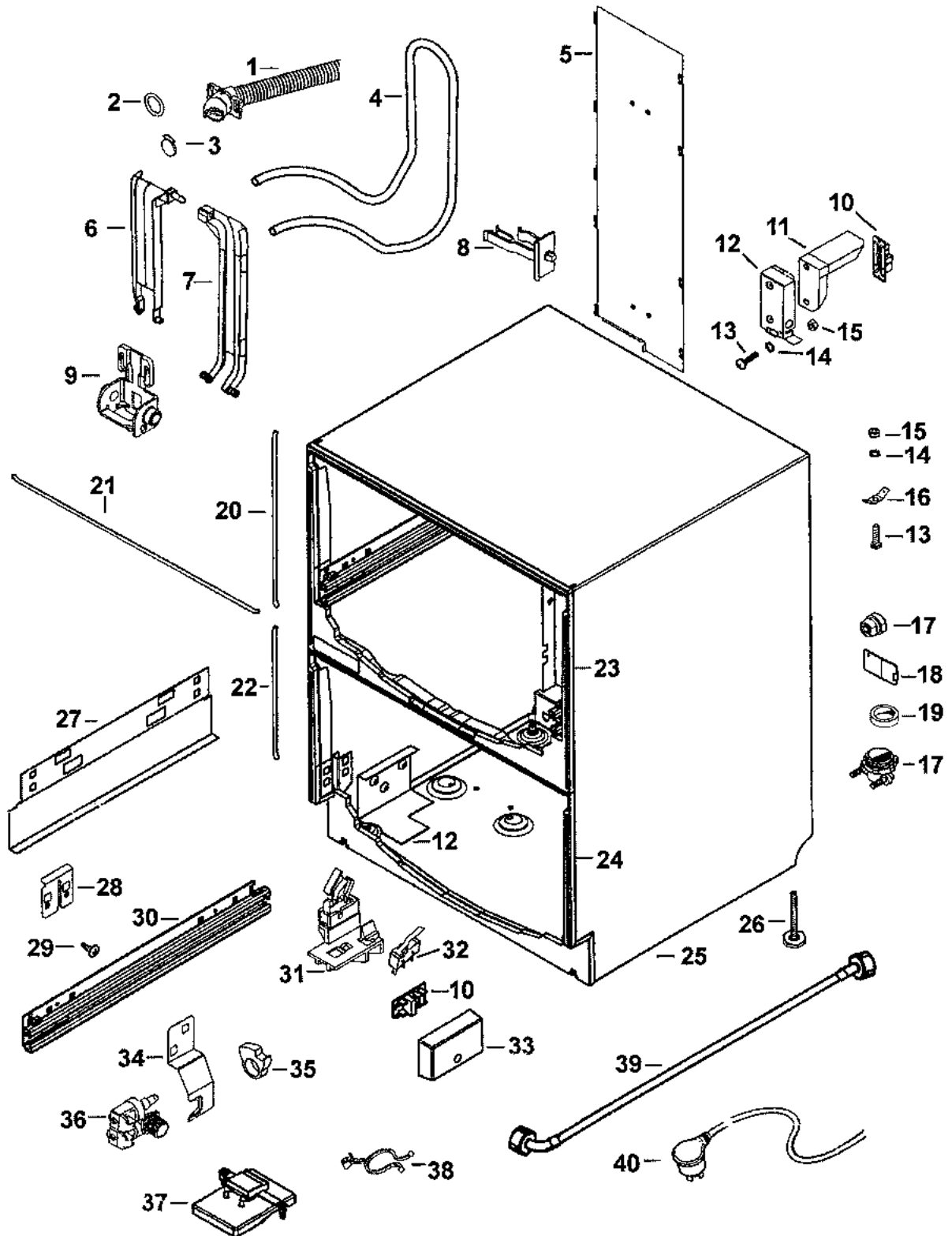

**CABINET**

<b>REF</b>	<b>PART</b>	<b>DESCRIPTION</b>	<b>MODEL</b>
1	527137	KIT DRAIN HOSE	
2	525940P	O RING CUFF SOCKET UL REC PKT4	
3	525414P	KIT VALVE FLAP (PKT 2)	
4	526836	HOSE FILL UPPER WRC	
	526837	HOSE FILL LOWERWRC	
5	525168	REAR PANEL COVER DOUBLE	
	525179	REAR PANEL COVER SINGLE	
6	525060	LINK CHASSIS SIDE	
7	525061	LINK TUB SIDE	
8	525108	CLIP DRAIN HOSE (RED)	
9	525166	LINK CHASSIS MOUNT	
10	525908P	PCB ASSY MAINS EMI FILTER	601V2
	525934P	MAINS FILTER 525 PH2 120V SGL	602
	525304P	MAINS FILTER 525 PH1 SINGLE	601
11	525887	INSULATOR EMI FILTER	
12	525841	EMI MOUNT	601V2, 602
	# 525784	BRACKET EMI	601
13	556022P	SCREW MC M5X20 PAN PH MS NP PKT10	
14	556513P	WASHER LOCK 5/32 EXT SER PKT10	
15	556105P	NUT M5 HEX FS MS NIPL PKT10	
16	525368	TERM EARTH POST QC 6.3 M H1166	
17	525897	CLAMP CABLE NEER C500 3/8"	601V2, 602
	388652	GROMMET CORD GRIP Q6543	601
18	526024	COVER HOSE EXTERNAL	
19	525795	525 TOROID ZW-42507-TC	601
20	525397	SEAL SOUND SIDE LONG(350MM) GY	
	525717	SEAL SOUND SIDE LONG(350MM)BK	
21	525396	SEAL SOUND TOP (554MM) GREY	
	525716	SEAL SOUND TOP (554MM) BLACK	
22	525398	SEAL SOUND SIDE SHORT(264MM)GY	
	525719	SEAL SOUND SIDE SHORT(264MM)BK	
23	* 528152	KIT CHASSIS TRIM PH2 TOP	
		TRIM CHASSIS BLACK	
	525716	SEAL SOUND TOP (554MM) BLACK	
	525717	SEAL SOUND SIDE LONG(350MM)BK x2	

# CABINET

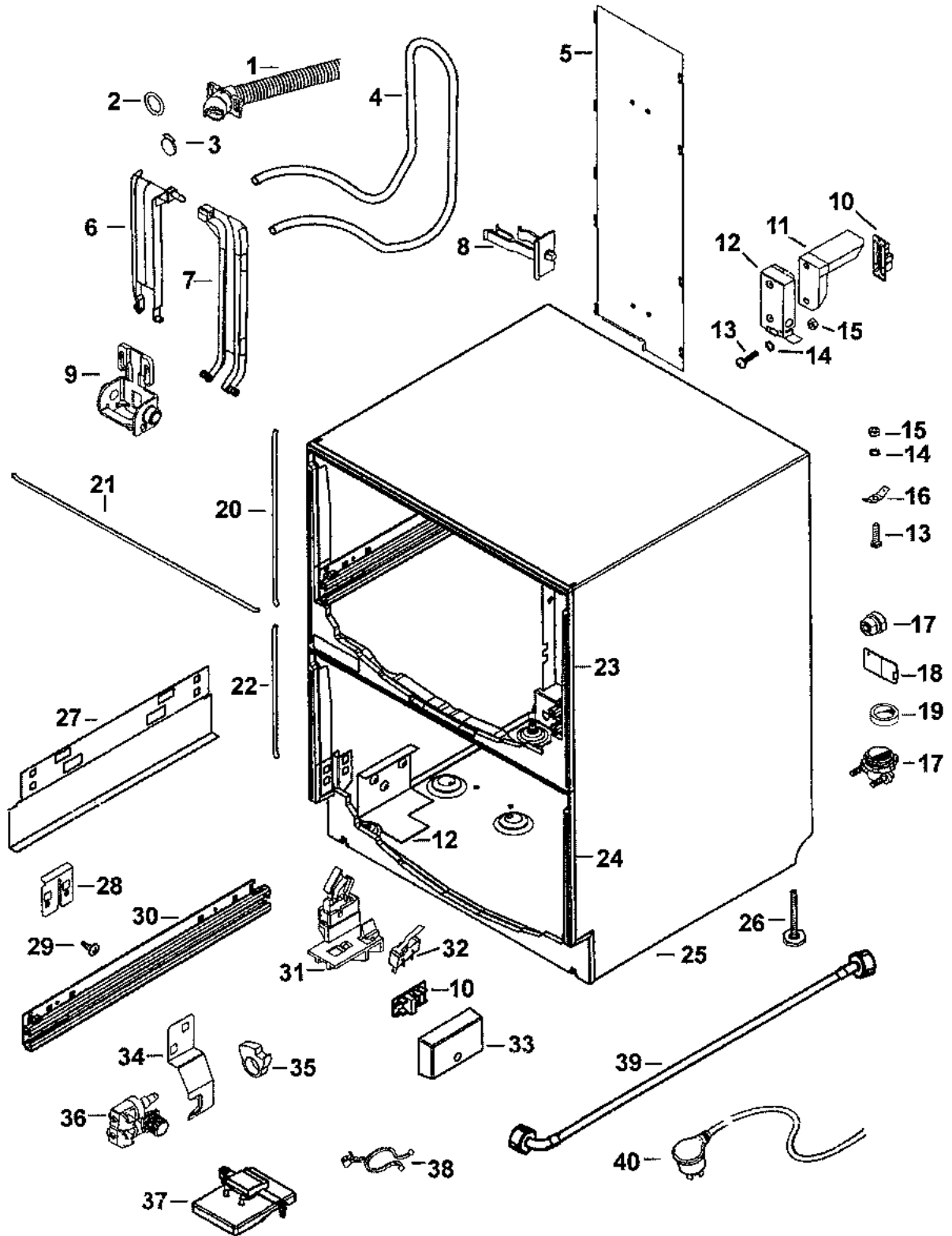

**CABINET**

<b>REF</b>	<b>PART</b>	<b>DESCRIPTION</b>	<b>MODEL</b>
24	* 528153	KIT CHASSIS TRIM PH2 BOTTOM TRIM CHASSIS KICKSTRIP BLACK <i>525716 SEAL SOUND TOP (554MM) BLACK</i> <i>525719 SEAL SOUND SIDE SHORT(264MM)BK x2</i>	
25	526662	CHASSIS REPLACE SGL ZW/INT/SS	
	526658	CHASSIS REPLACE DBL ZW/INT/SS	
26	526332	FOOT	
27	525737	BRACKET LID SUPPORT	
28	525002	STIFFENER CHASSIS LH	
	525003	STIFFENER CHASSIS RH	
29	556088P	SCREW ST M6X13TAPTITE CSK PKT10	
30	525131	SLIDE R H LONG	
	525132	SLIDE L H LONG	
	525763	SLIDE R H SHORT	
	525764	SLIDE L H SHORT	
31	525791	BRACKET LATCH ASSY L H	
	525792	BRACKET LATCH ASSY R H	
32	525893	MICROSWITCH TUB HOME	601V2, 602
33	525782	COVER EMI	601
34	525291	BRACKET INLET VALVE	
35	525466	CLAMP HOSE HERBIE TYPE E	
36	525113	VALVE INLET DOUBLE 4L	
	525842	VALVE INLET SINGLE 4L	
37	525941	SWITCH FLOOD UL REC US <i>521539 SWITCH FLOOD FLOAT</i>	
38	572714	CLIP CABLE TWIST HOLDER ID24MM	
39	521349	HOSE INLET ASSY WIRSBO COLD	
	525937	HOSE ASSY INLET USA	
40	525983	FLEX ASSY MAINS US	602
	525900	FLEX ASSY MAINS 10A	601V2
	525109	FLEX ASSY MAINS 10A	601
NI	525802	DRAIN HOSE SLEEVE	
NI	525938	WASHER WIRSBO US	
NI	556118P	NUT M8 HEX 13AF FS MS PKT10	
NI	526023	FOOT LOCKNUT INSERT	

# DRAWER LID AND AIR PUMP

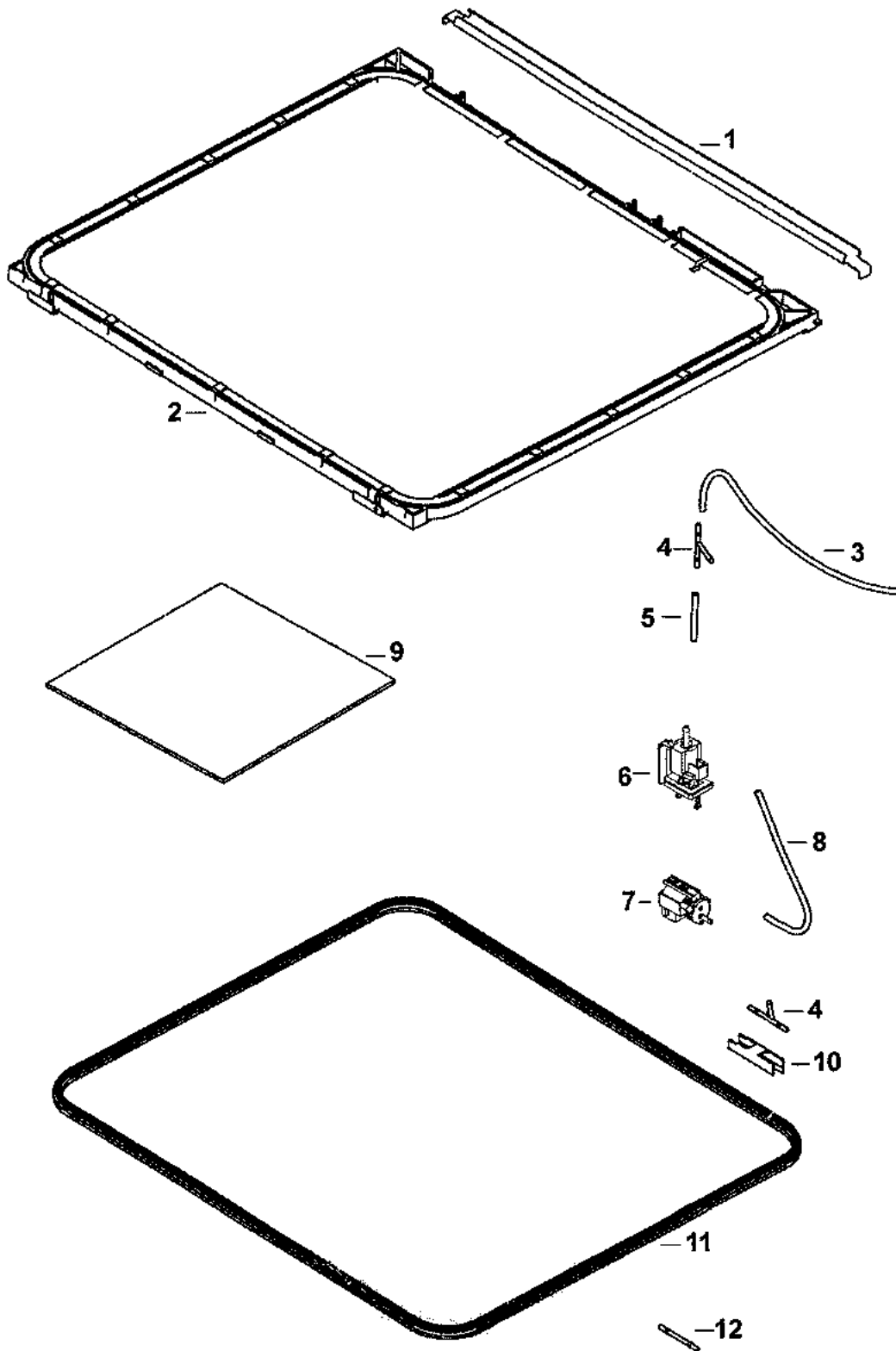

**DRAWER LID AND AIR PUMP**

<b>REF</b>	<b>PART</b>	<b>DESCRIPTION</b>	<b>MODEL</b>
1	525370	BRACE LID REAR	
2	* 525876P	KIT LID SERVICE	
3	525427	AIR HOSE SEAL (BUTT)	
4	525341	GASKET AIR Y CONNECTOR	601
5	525491	AIR HOSE EXHAUST VALVE	
6	* 528148	KIT PH2 PUMP / EXHAUST VALVE	
		VALVE EXHAUST ASSY LID GASKET	
		AIR PUMP ASSY LID GASKET	
	555993	CONNECTOR RAST 7234-003-501-45 x2	
7	* 528148	KIT PH2 PUMP / EXHAUST VALVE	
		VALVE EXHAUST ASSY LID GASKET	
		AIR PUMP ASSY LID GASKET	
	555993	CONNECTOR RAST 7234-003-501-45 x2	
8	525450	AIR HOSE PUMP	
9	526034	INSUL FELT TOP	
10	* 525781	LID SEAL DEFLECTOR	601
11	525031	LID SEAL	
	* 525878	LID SEAL (SP) - OVERLAPPING	
12	* 525873	STRAIGHT CONNECTOR (SP)	601V2, 602

# TUB AND COMPONENTS

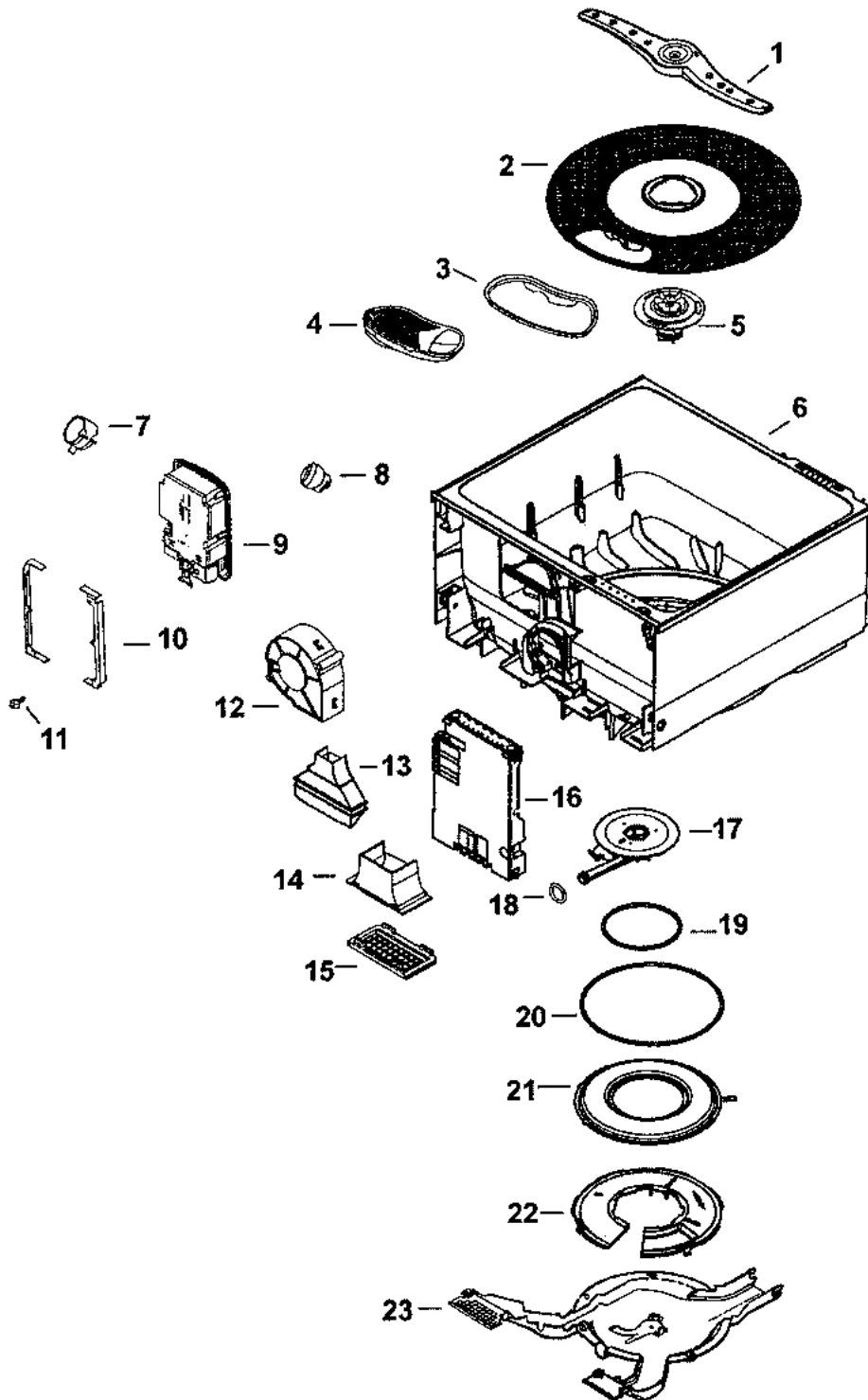



**TUB AND COMPONENTS**

<b>REF</b>	<b>PART</b>	<b>DESCRIPTION</b>	<b>MODEL</b>
1	527475	SPRAY ARM ASSY SLUICING 03 18H	
2	* 525882	FILTER PLATE ASSY	
	525315	<i>DRAIN FILTER TRIM</i>	
	526069	<i>LOCK NUT FILTER PLATE</i>	
3	525315	DRAIN FILTER TRIM	
4	525452	DRAIN FILTER ASSY	
5	525884P	MOTOR ROTOR ASSY	
6	525011	TUB ASSY	
7	525743	CLAMP HOSE TYPE 12232-17-4	
8	525610	DISPENSER RINSE AID BUNG ASSY	
9	526860	KIT DISPENSER	
		DISPENSER DISHDRAWER 2004	
		BRACKET DISPENSER SHORT x2	
10	525632	BRACKET DISPENSER	
11	556090P	SCREW ST M3X15PLASTIT PANTX (PKT10)	
12	525219	FAN DRYING	
13	525222	DUCT DRYING TOP ASSY	
14	525223	DUCT DRYING BOTTOM	
15	525218	GRILLE DRYING	
16	525832P	CONTROLLER MOTOR	601V2
	525872P	CONTROLLER 525 PH2 120V PACKED	602
	525189P	CONTROLLER MOTOR	601
	525896	<i>MICROSWITCH ARM ASSY (SP)</i>	
17	528041	KIT MOTOR ASSY PH2	
		MOTOR 6 POLE ASSY COMP PH2	
	525940P	<i>O RING CUFF SOCKET UL REC</i>	
	525058	<i>SEAL HEATER PLATE/TUB</i>	
	525059	<i>SEAL MOTOR HOUSING</i>	
18	525940P	O RING CUFF SOCKET UL REC PKT4	
19	525059	SEAL MOTOR HOUSING	
20	525058	SEAL HEATER PLATE/TUB	
21	525169	HEATER PLATE ASSY 230-240V	
	527700	KIT HEATER PLATE PH2 US	
22	525162	LOCKING NUT	
23	525903	COVER WIRING VO UL REC US	
NI	525839	TRIM INTEGRATED GREY	

# BASKETS AND RACKS

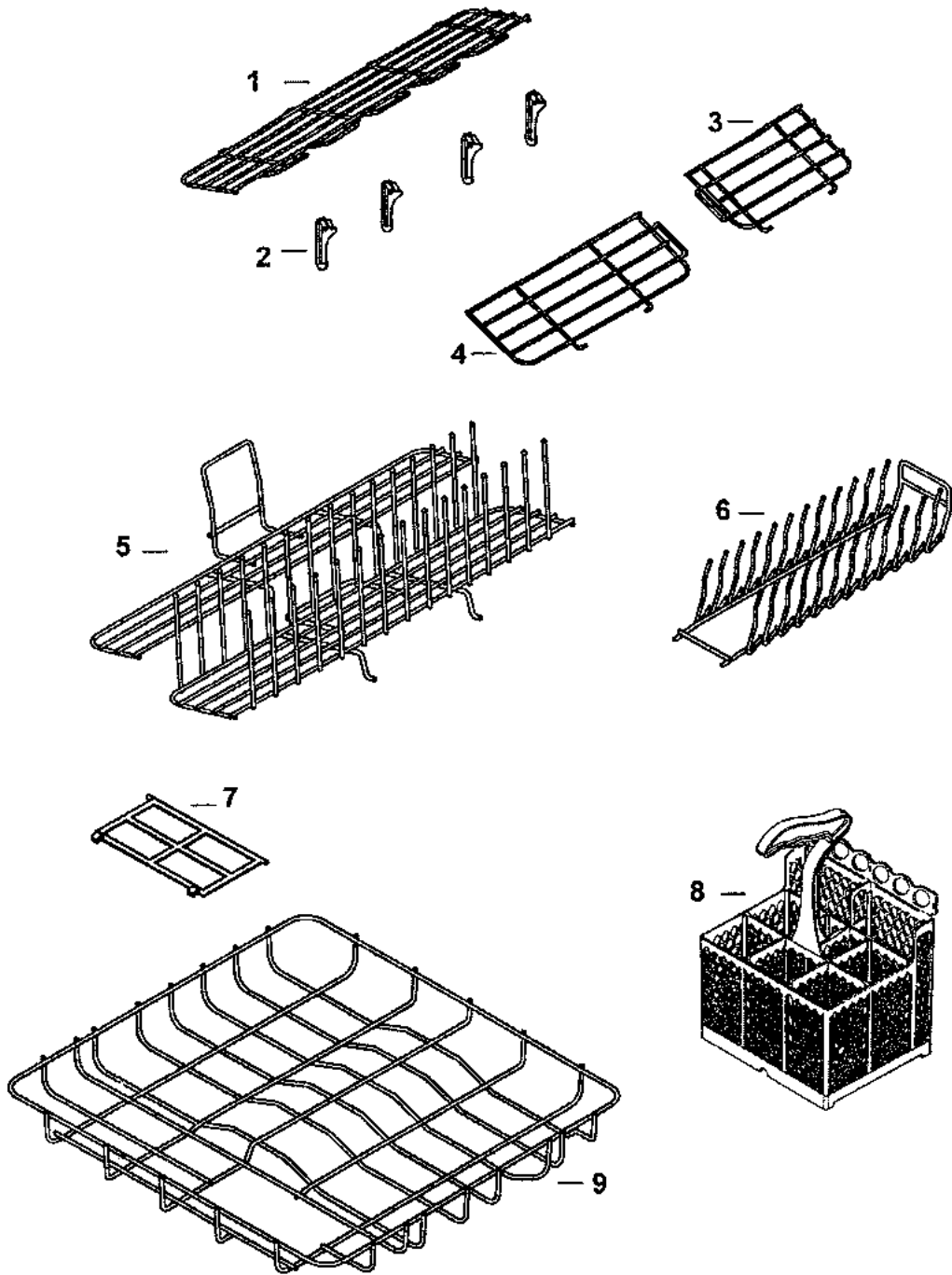

**BASKETS AND RACKS**

<b>REF</b>	<b>PART</b>	<b>DESCRIPTION</b>	<b>MODEL</b>
1	525767	FOLD DOWN FULL LGTH ASY SILVER	
2	525200	CUP RACK POST	
3	525765	FOLD DOWN NARROW RH ASY SILVER	
4	525766	FOLD DOWN WIDE RH ASSY SILVER	
5	526346	UNI INSERT SILVER	
6	525769	CROCKERY INSERT ASSY SILVER	
7	526345	TRAP DOOR DRAIN FILTER ACCESS	
8	525489	CUTLERY CONTAINER ASSY	
9	526062	BASKET SILVER	
NI	* 525550	FOLD DOWN BACK LEFT (PLASTIC)	
	* 525551	FOLD DOWN FRONT LEFT (PLASTIC)	
	* 525552	FOLD DOWN FRONT RIGHT (PLASTIC)	
	* 525553	FOLD DOWN BACK RIGHT (PLASTIC)	

# WIRING HARNESSES

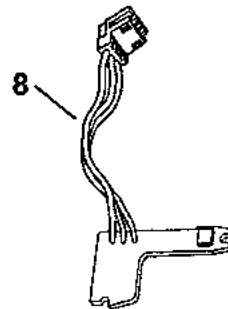
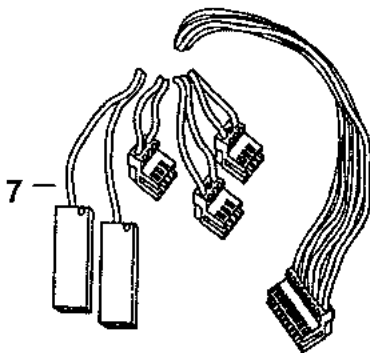
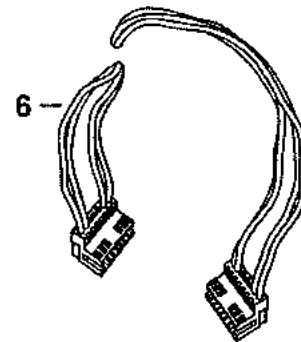
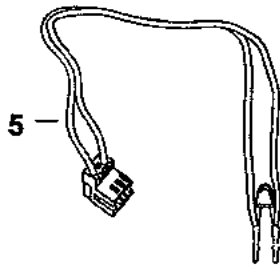
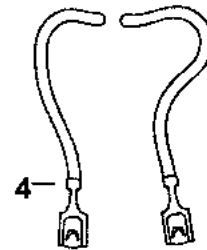
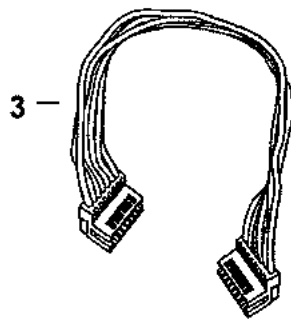
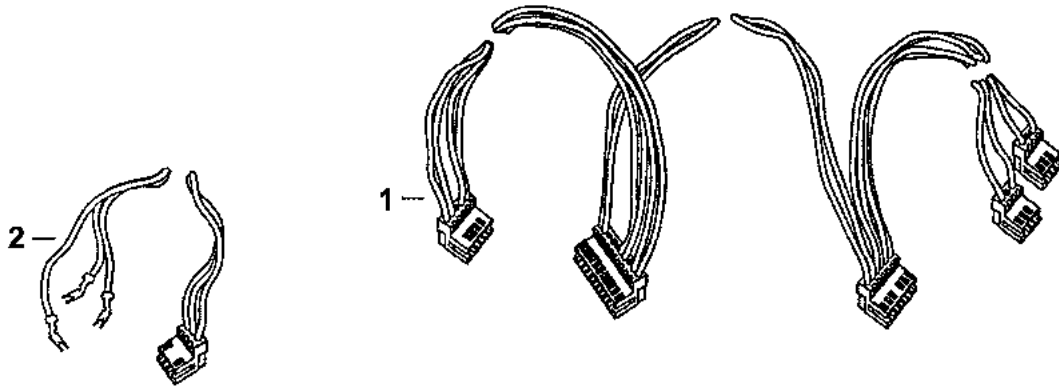

**WIRING HARNESSSES**

<b>REF</b>	<b>PART</b>	<b>DESCRIPTION</b>	<b>MODEL</b>
1	525831	HARNESS PCB SIDE PH2	601V2, 602
	525334	HARNESS PCB SIDE	601
2	525402	HARNESS MOTOR	601
3	525879	HARNESS LCD BOARD PH2	
4	# 555517	WIRE ELEMENT EARTH 1400MM	
	# 555518	WIRE ELEMENT EARTH 1000MM	
5	525330	HARNESS RINSE AID LED	601
6	525880	HARNESS MAINS UPPER PH2	601V2, 602
	525881	HARNESS MAINS LOWER PH2	601V2, 602
	525401	HARNESS MAINS LOWER (WHITE)	601
	525409	HARNESS MAINS UPPER (BLUE)	601
7	525901	HARNESS CHASSIS LOWER PH2	601V2, 602
	525902	HARNESS CHASSIS UPPER PH2	601V2, 602
	525404	HARNESS CHASSIS LOWER (BLUE)	601
	525410	HARNESS CHASSIS UPPER (RED)	601
8	525869P	HALL SENSOR 525 SINGLE	

# INSTALLATION COMPONENTS

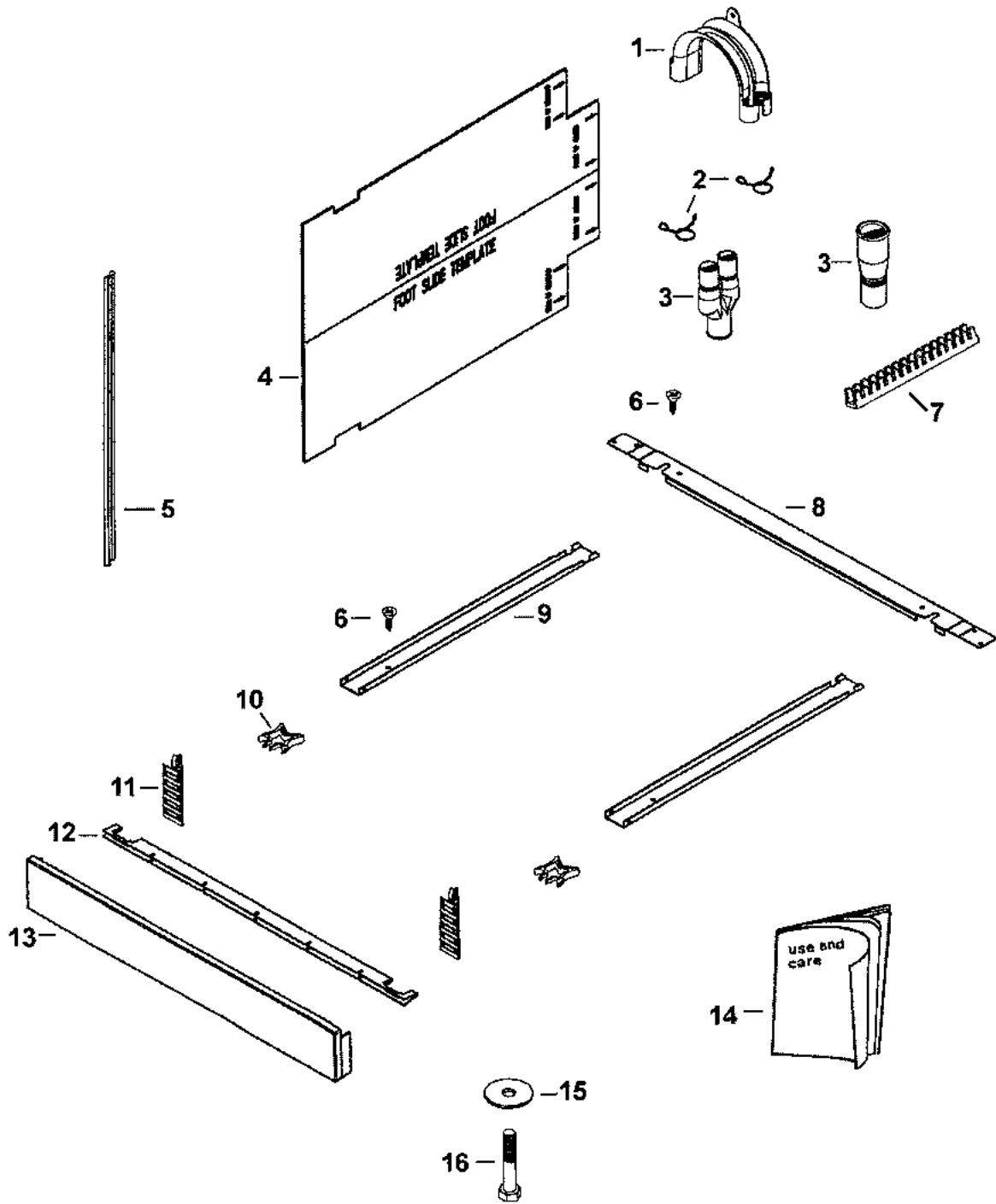

**INSTALLATION COMPONENTS**

<b>REF</b>	<b>PART</b>	<b>DESCRIPTION</b>	<b>MODEL</b>
1	525477F	SUPPORT DRAIN HOSE	
2	525482P	CLIP WIRE DRAIN PKT2	
3	525067	DRAIN SPIGOT CONNECTOR DOUBLE	
	525460	DRAIN SPIGOT CONNECTOR SINGLE	
	525925	DRAIN SPIGOT CONNECTOR DOUBLE USA	
	525926	DRAIN SPIGOT CONNECTOR SINGLE USA	
4	525886	TEMPLATE SINGLE	
	526040	FOOT SLIDE FULL TEMPLATE	
5	525920	TRIM CAVITY GREY USA	
	525921	TRIM CAVITY BLACK USA	
6	556089P	SCREW WS 8X5/8TWINFST PKT10	
	556092P	SCREW ST 8X1TWINFAST TS PKT10	
7	525935	TRIM EDGE PROTECTION USA	
8	525088	CHANNEL TRANSVERSE	
9	525049	CHANNEL LONGITUDINAL	
10	525313	CLIP PEG	
11	525724	KICKSTRIP PIN BLACK	
12	525451	BRACE KICKSTRIP	
13	525286	KICKSTRIP COSMETIC LOWER WHITE	
	525723	KICKSTRIP COSMETIC LOWER BLACK	
14	525794	BOOK USE & CARE DD601	601
	* 525838	BOOK USE & CARE DD601I	601I
	* 525929	BOOK USE & CARE DD601V2	601V2
	525930	BOOK USE & CARE DD601IV2	601V2I
	* 525911	BOOK USE & CARE	602
	* 525912	BOOK USE & CARE	602I
15	556525P	WASHER 31.7 8.5 1.6 MS ZP PKT10	
16	556093P	SCREW MC M8X45 HEX FS MS PKT10	
NI	526023	FOOT LOCKNUT INSERT	
NI	# 599065	CARD INSTAL INSTR DD DBL US	602
	# 599066	CARD INSTAL INSTR DD SGL US	602
	599068	CARD INSTAL INSTR SGL ANZ	601, 601V2
	# 525779	CARD INSTAL INSTR DD601 ANZ	601
	599067	CARD INSTAL INSTR DBL ANZ	601V2

# INSTALLATION COMPONENTS

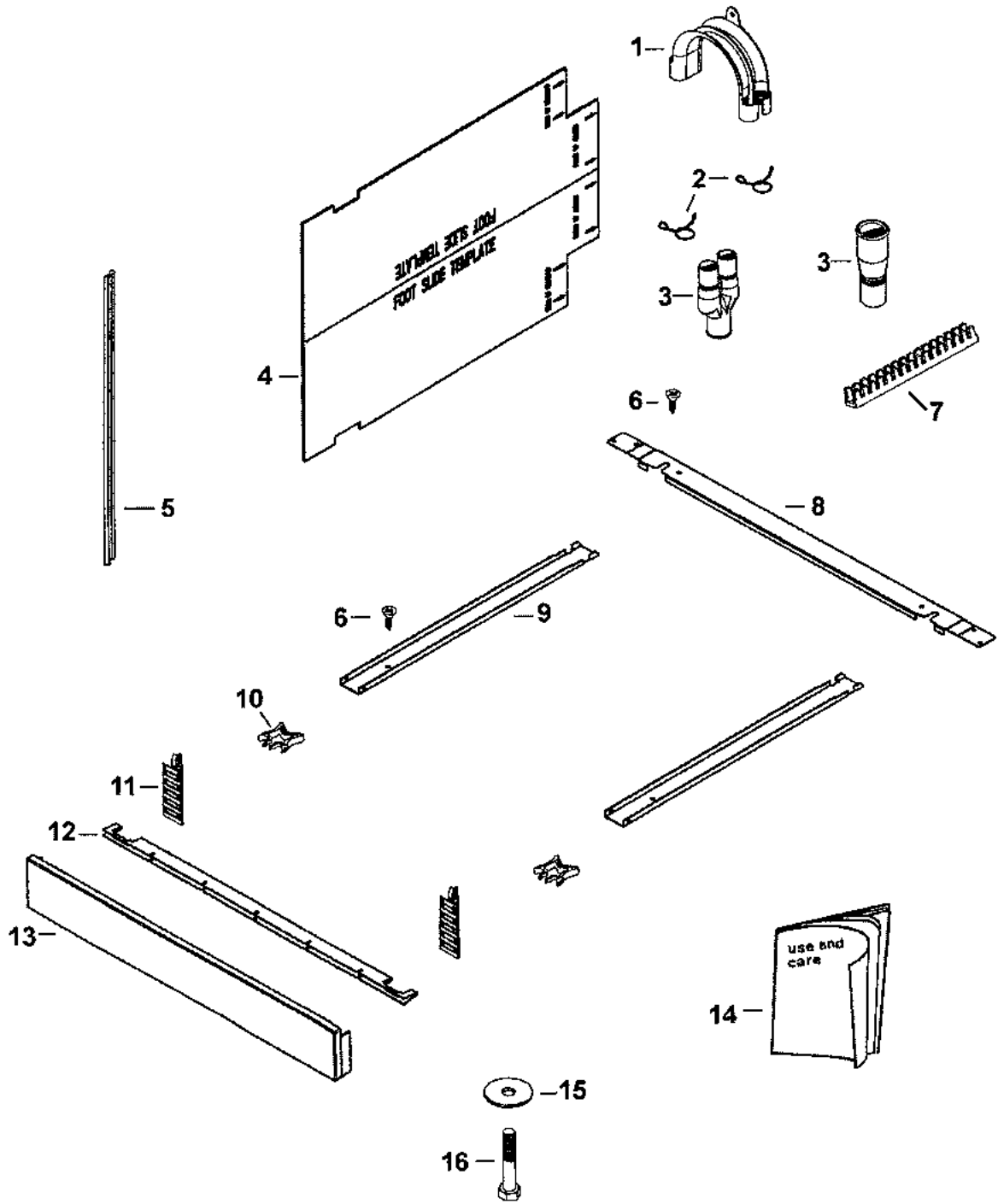



**INSTALLATION COMPONENTS**

<b>REF</b>	<b>PART</b>	<b>DESCRIPTION</b>	<b>MODEL</b>
NI	525798	KIT DRAIN HOSE EXTENSION 3.6M DRAIN HOSE EXTENSION X2	
	525482	<i>CLIP WIRE DRAIN X4</i>	
	525780	<i>DRAIN HOSE JOINER X2</i>	
NI	526085	TRIM CAVITY TOP GREY US	
	526086	TRIM CAVITY TOP BLACK US	
NI	526053	ENDPLATE ASSY BLACK	
NI	526676	KIT INSTALL DOUBLE/SINGLE US	
	525477F	<i>SUPPORT DRAIN HOSE</i>	
	525925	<i>DRAIN SPIGOT CONNECTOR DBL US</i>	
	525926	<i>DRAIN SPIGOT CONNECTOR SGL US</i>	
	525482	<i>CLIP WIRE DRAIN x2</i>	
	556089P	<i>SCREW WS 8X5/8TWINFST MTSPH ZP x7</i>	
	525938	<i>WASHER WIRSBO US</i> CLAMP HOSE DIA 32-14	
	525953	<i>CLAMP HOSE DIA 32-20</i>	
	525935	<i>EDGE 160MM 22PKG020 UHMWPE US</i> TRIM CAVITY SIDE DBL CHARCL US x2 TRIM CAVITY SIDE SGL CHARCL US x2 TRIM CAVITY TOP CHARCOAL US	
	526797	<i>TAB TOP x2</i>	



## NOTES

### FRONT PANELS AND CONTROLS

#### Technical Bulletins

525185P            DW007

### CABINET

#### Technical Bulletins

528152, 528153    DW047

### DRAWER LID AND AIR PUMP

#### Notes

525876P            Introduction of new lid from S/N AID525941, along with the overlapping lid seal.

#### Technical Bulletins

525781            DW002  
 525873            DW002  
 525878            DW002  
 528148            DW047

### TUB AND COMPONENTS

#### Technical Bulletins

525882            DW002  
 525736            DW003, DW005

### BASKETS AND RACKS

#### Technical Bulletins

525550, 525551,    DW016  
 525552, 525553

### INSTALLATION COMPONENTS

#### Notes

525838, 525929,    Books only available from the Fisher & Paykel website  
 525911, 525912    [www.fisherpaykel.co.nz](http://www.fisherpaykel.co.nz)